

# Charmonium production with $e^+e^-$

P.Pakhlov  
(ITEP, Moscow)



## OUTLINE

- Few words about Tevatron  $\psi'$  surplus problem
- Charmonium production in  $\gamma\gamma$
- Charmonium production at B-factories
- Double charmonium production at Belle
- $J/\psi$  production with associated charm hadrons at Belle
- Summary

XXXIII International Symposium on Multiparticle Dynamics

*Krakow, Poland, September 5-11, 2003*

# Charmonium production in $p\bar{p}$

Mechanisms for charmonium production in a variety of processes (hadronic & photoproduction;  $B$ -decays;  $\gamma\gamma$ ;  $e^+e^-$ ) remain a puzzle for many years

## Tevatron $\psi(2S)$ surplus problem

Perturbative QCD: the leading mechanism for high- $p_T$   $\psi(2S)$  is  $c$ -quark fragmentation

The measured cross-section  $\sim 30$  larger than PQCD expectations

Color Octet Mechanism:  
 $g \rightarrow (cc)^8 \rightarrow \psi(2S) n g_{soft}$

- describes **well** cross-section and  $p_T$  spectrum
- predicts **poor**  $J/\psi$  and  $\psi(2S)$  polarization

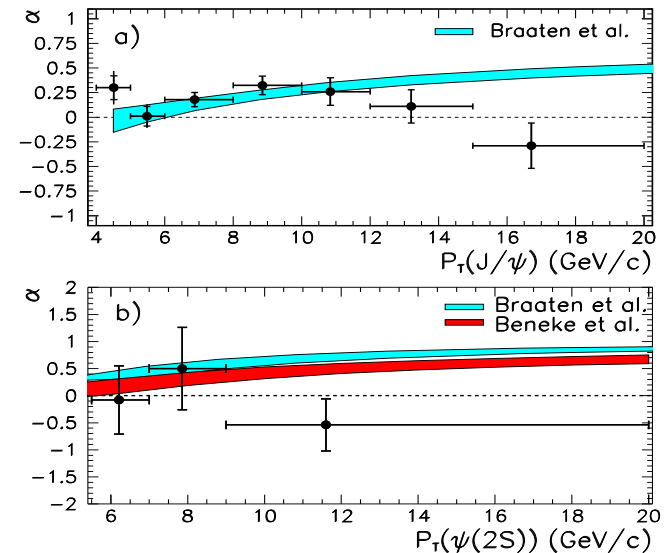
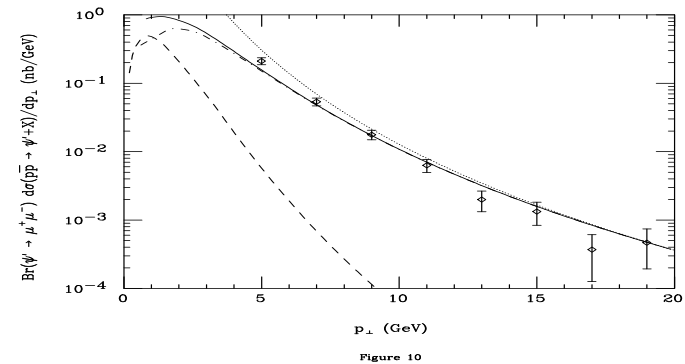



# Charmonium production in $\gamma\gamma$

Production at  $Q_{\gamma\gamma}^2 \sim M_{(c\bar{c})_{res}}^2$

BaBar, Belle and CLEO (2003):  
First observation of  $\gamma\gamma \rightarrow \eta_c(2S)$

Only the CLEO results is shown

$$\mathcal{L} = (13.4 + 9.2)\text{fb}^{-1}$$

$$\eta_c(2S) \rightarrow K_S K \pi$$

$$M(\eta_c(2S)) = 3642.7 \pm 4.1 \pm 4.0 \text{ MeV}/c^2$$

$$\frac{\Gamma_{\gamma\gamma}(\eta_c(2S)) \times \mathcal{B}(\eta_c(2S) \rightarrow K_S K \pi)}{\Gamma_{\gamma\gamma}(\eta_c) \times \mathcal{B}(\eta_c \rightarrow K_S K \pi)} = 0.17^{+0.07}_{-0.06} \pm 0.04$$

Confirms Belle observation of  $\eta_c(2S)$  in  $B$  decays and in double  $c\bar{c}$  production.

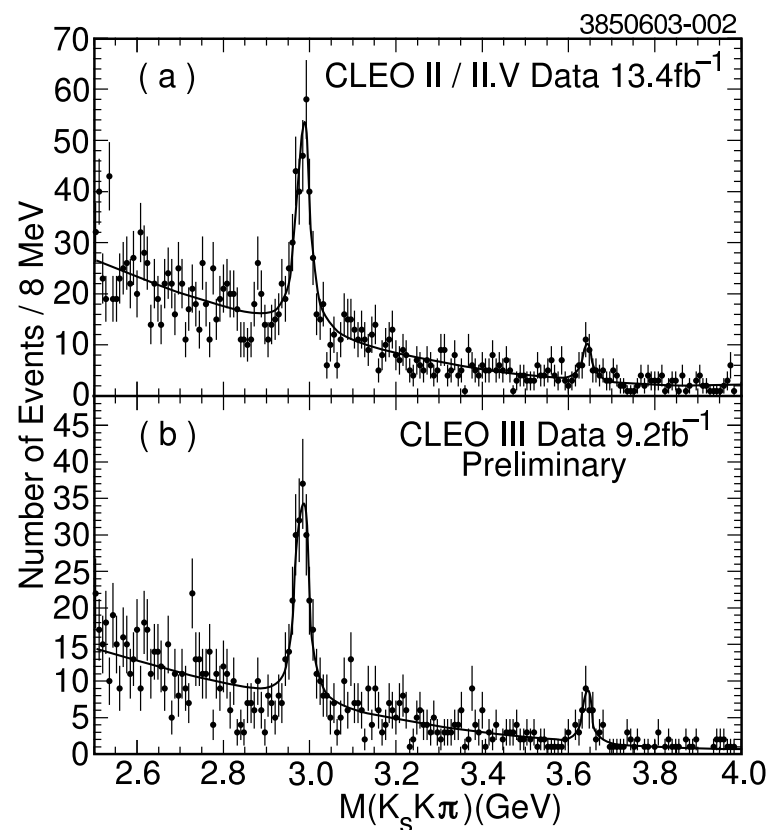
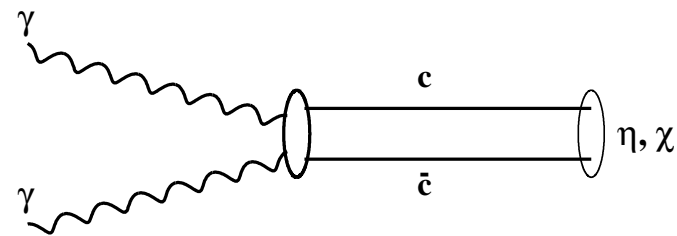



# Charmonium production in $\gamma\gamma$

Production at  $Q_{\gamma\gamma}^2 \gg M_{(c\bar{c})_{res}}^2$

Two mechanisms:

- Resolved gluon production (Color singlet + Color octet)
- Vector-meson dominance (Pomeron exchange + diffractive photon dissociation)

New DELPHI measurement  $\gamma\gamma \rightarrow J/\psi X$   
 $\mathcal{L} = 617 \text{ pb}^{-1}$ ;  $\sqrt{s} = 161 - 207 \text{ GeV}$

- $N(J/\psi \rightarrow \mu^+ \mu^-) = 36 \pm 7$  events
- Estimated fraction of resolved (CS+CO) =  $(74 \pm 22)\%$  from the fit to  $p_{\perp}$  distribution
- Favor LARGE Color Singlet contribution
- $\sigma(\gamma\gamma \rightarrow J/\psi X) = 45 \pm 9 \pm 17 \text{ pb}$

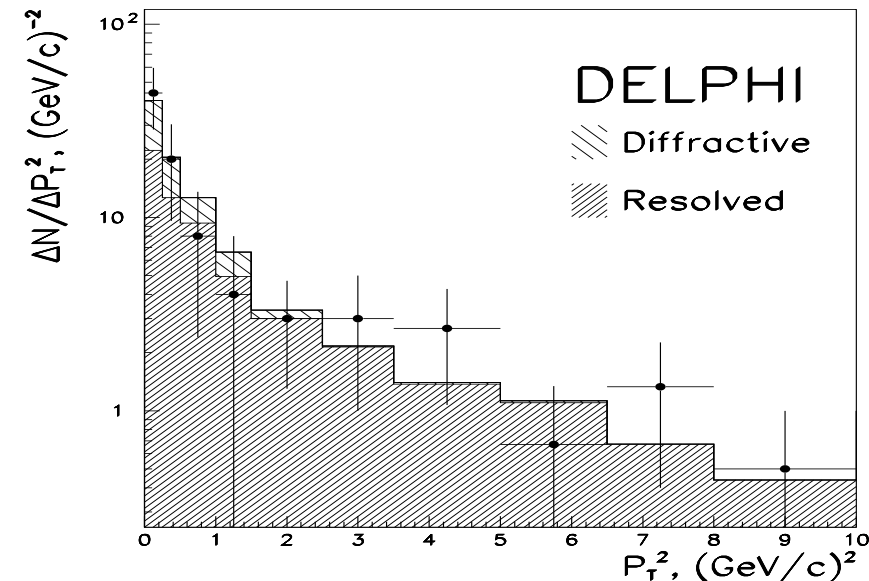
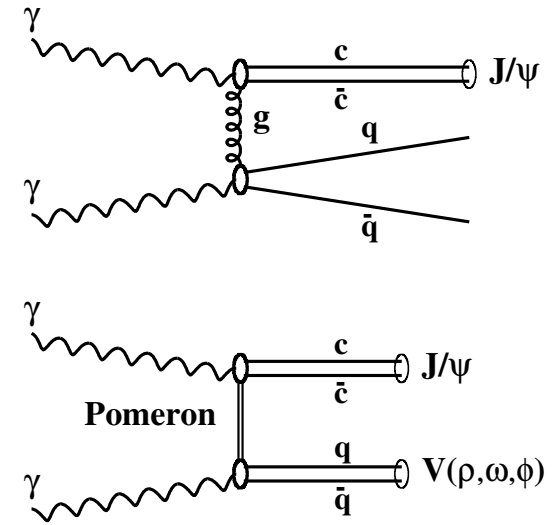



# $J/\psi$ production in $e^+e^-$

**BIG SURPRISE #1:**  
**Charmonium production in  $e^+e^-$  was not predicted by theory but first observed experimentally**

CLEO: “*Observation of  $\Upsilon(4S)$  Decays into non- $B\bar{B}$  Final States Containing  $\psi$  Mesons*” (1990)

- 15.2 $^{+4.9}_{-4.5}$   $J/\psi$  events are observed above kinematical limit for  $B$ -decays ( $p > 2\text{ GeV}/c$ ) in  $\Upsilon(4S)$  data
- No significant signal in continuum +  $\Upsilon(5S)$  data
- Misinterpreted as direct  $\Upsilon(4S)$  decays into  $J/\psi$   
 $\downarrow$   
Many exotic models to explain  $\Upsilon(4S) \rightarrow J/\psi X$
- With new data  $J/\psi$  signal was observed in the continuum
- $\sigma(e^+e^- \rightarrow J/\psi X) \sim 2\text{ pb}$

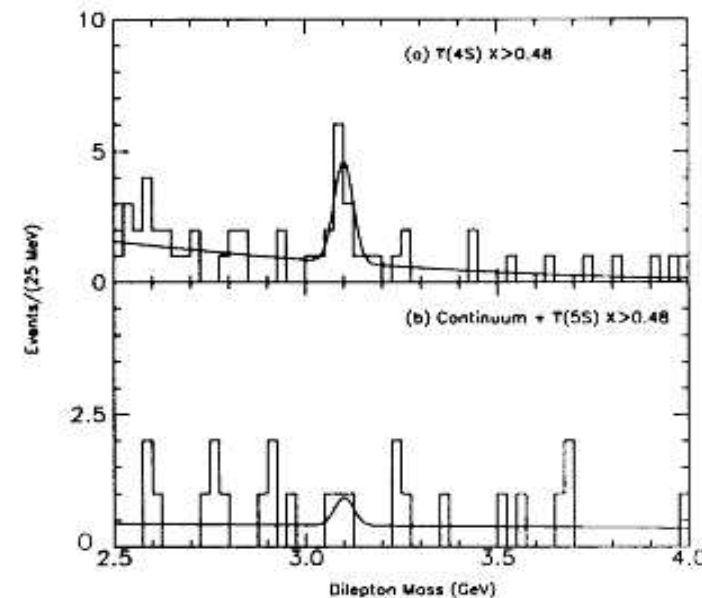

# Theoretical overview

Three processes are considered to describe charmonium production

Color Singlet  $e^+e^- \rightarrow \gamma^* \rightarrow J/\psi gg$

Cho & Leibovich, **PRD** 53, 150 (1996)

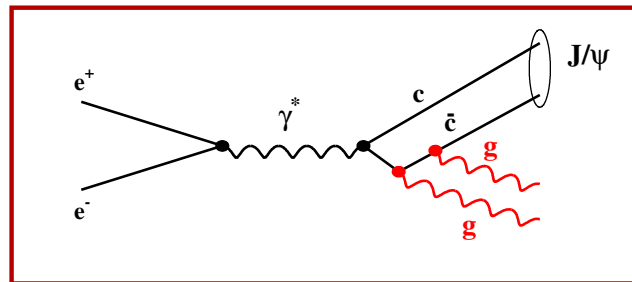

$\sim 1 \text{ pb}$

Color Octet  $e^+e^- \rightarrow \gamma^* \rightarrow J/\psi g$

Braaten & Chen, **PRL** 76, 730 (1996)

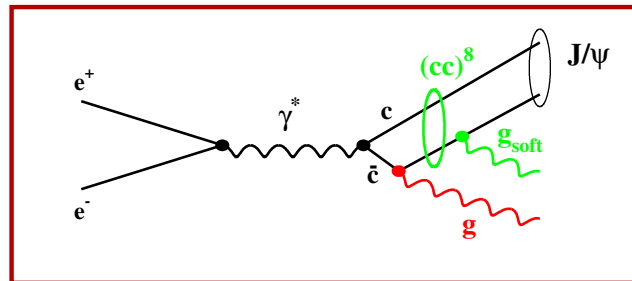

$0.05 - 0.5 \text{ pb}$   
significant around  
endpoint of  $J/\psi$   
spectrum

Color Singlet  $e^+e^- \rightarrow \gamma^* \rightarrow J/\psi c\bar{c}$

Kiselev *et al.* **PLB** 411, 150 (1994)

P.Cho & A.K.Leibovich (1996)

S.Baek *et al.* (1998)

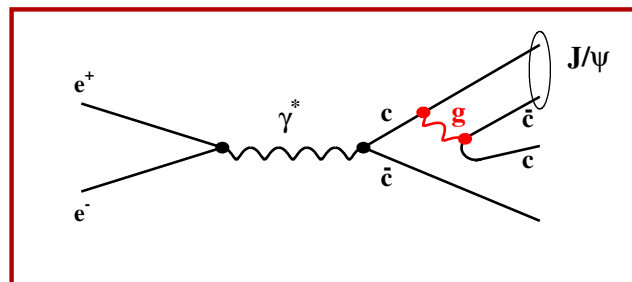

$0.05 - 0.07 \text{ pb}$



# Continuum $J/\psi$ production at B-factories

**B-factories intensively studied charmonium production in  $e^+e^-$**

BaBar: “Measurement of  $J/\psi$  production in continuum  $e^+e^-$  annihilation near  $\sqrt{s} \approx 10.6 \text{ GeV}$ ” (PRL 87, 162002 (2001))

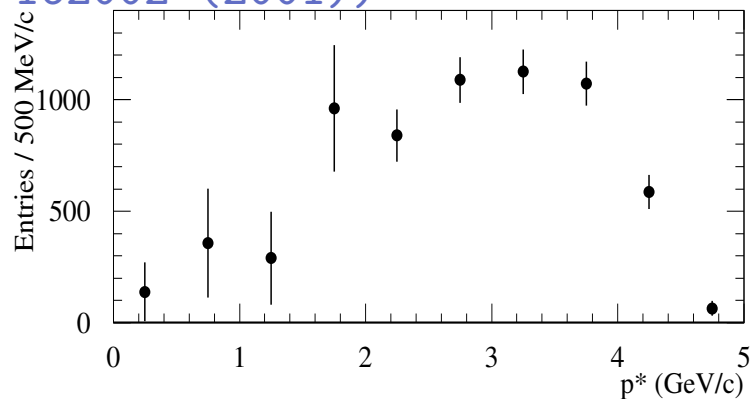

$$\sigma(e^+e^- \rightarrow J/\psi X) = 2.52 \pm 0.21 \pm 0.21 \text{ pb}$$

Belle: “Production of Prompt Charmonia in  $e^+e^-$  Annihilation at  $\sqrt{s} \approx 10.6 \text{ GeV}$ ” (PRL 88, 052001 (2001))

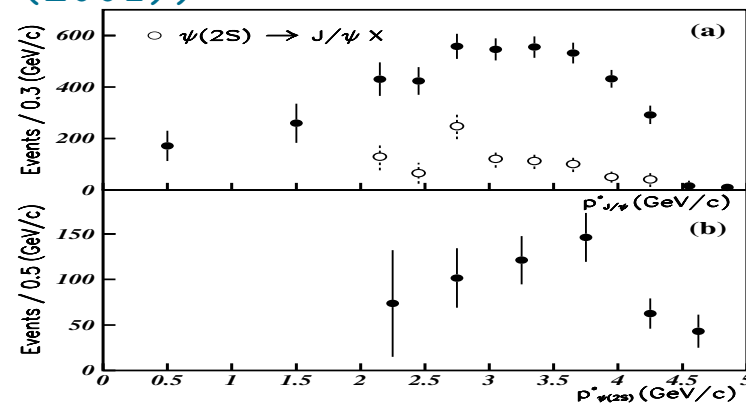

$$\sigma(e^+e^- \rightarrow J/\psi X) = 1.47 \pm 0.10 \pm 0.11 \text{ pb}$$

$$\sigma(e^+e^- \rightarrow \psi(2S)X) = 0.67 \pm 0.09^{+0.09}_{-0.11} \text{ pb}$$



# Study of continuum $J/\psi$

## $J/\psi$ production and helicity angles

BaBar:

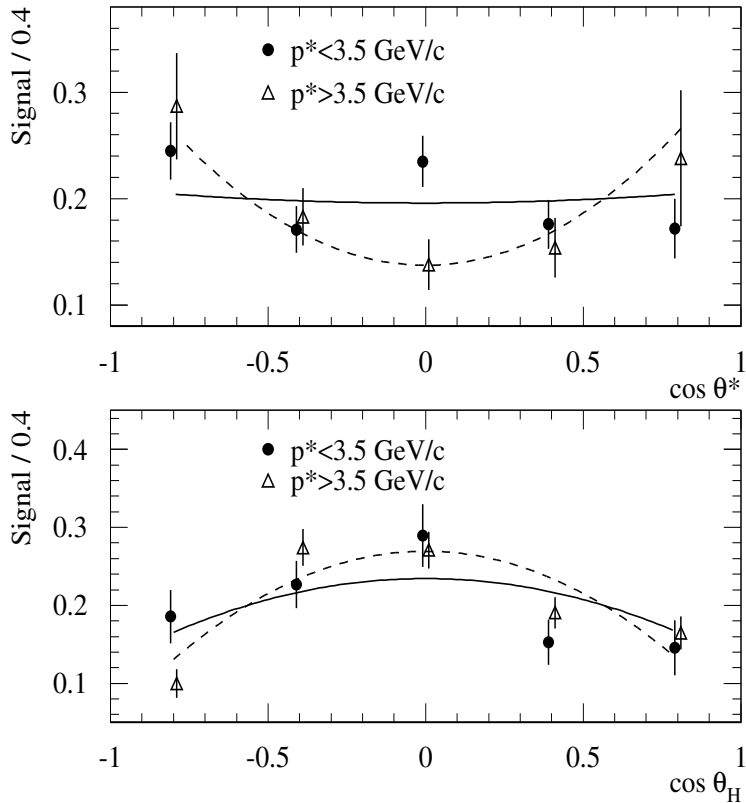

Belle:

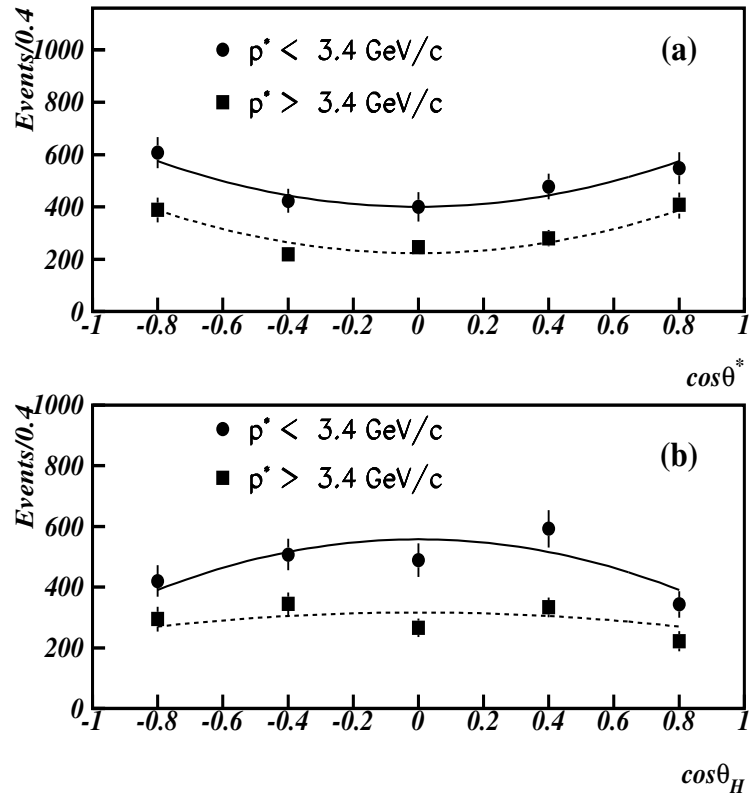

**Agreement between BaBar and Belle is poor;  
Both experiments favor Color Singlet model**

## BIG SURPRISE #2:

*Belle* observed many processes with prompt  $J/\psi$  accompanying by charm particles (PRL 89, 142001 (2002)):

### Threshold in $J/\psi$ recoil mass

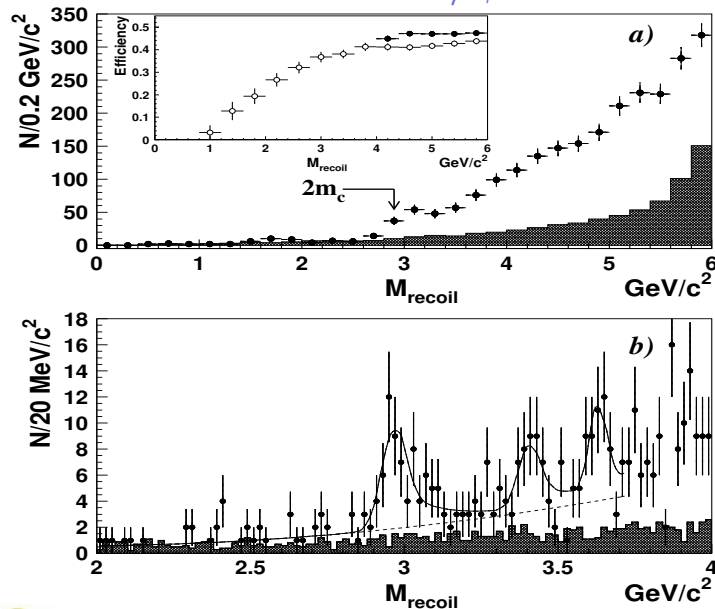

### Charmonium in $J/\psi$ recoil mass

spectrum

$$\sigma(e^+e^- \rightarrow J/\psi c\bar{c})/\sigma(e^+e^- \rightarrow J/\psi X) = (0.59_{-0.13}^{+0.15} \pm 0.12)$$

$$\sigma(e^+e^- \rightarrow J/\psi \eta_c) \times \mathcal{B}(\eta_c \rightarrow > 2 \text{ charged}) = (0.033_{-0.006}^{+0.007} \pm 0.009) \text{ pb}$$

### $D^{*+}$ in $J/\psi$ event: $N = 10.5_{-3.0}^{+3.6}$

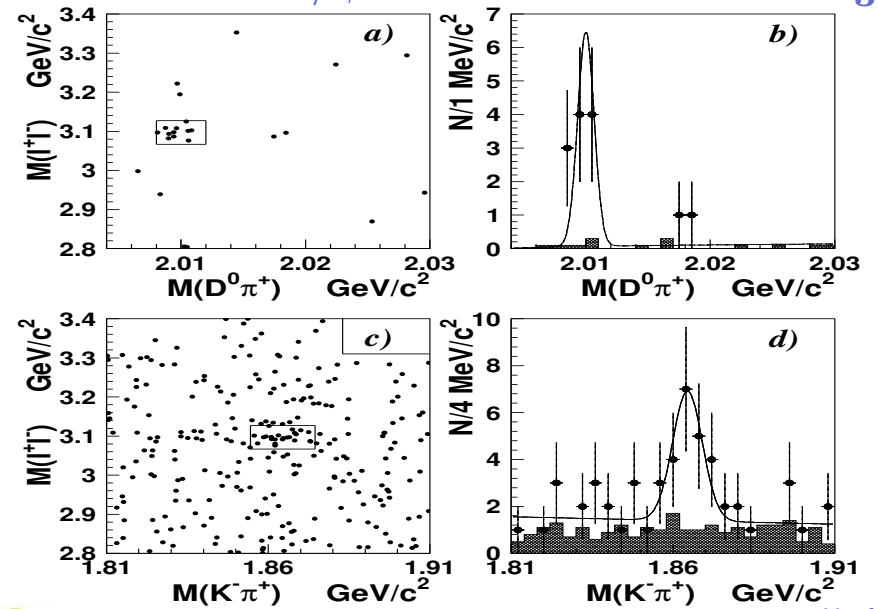

### $D^0$ in $J/\psi$ event: $N = 14.9_{-4.8}^{+5.4}$

# Attempts to explain Belle results

Measured cross sections exceeds the theory predictions by  $\sim 10$

- for  $e^+e^- \rightarrow J/\psi \eta_c$  (E.Braaten & J.Lee (2003))
- for inclusive  $e^+e^- \rightarrow J/\psi c\bar{c}$  (V.Kiselev *et al.* (1994); P.Cho & A.Leibovich (1996); E.Braaten & Y.Chen (1996))  
G.Bodwin, J.Lee, E.Braaten (2003)

Estimates are done for single virtual photon diagrams:

suggested new diagrams:

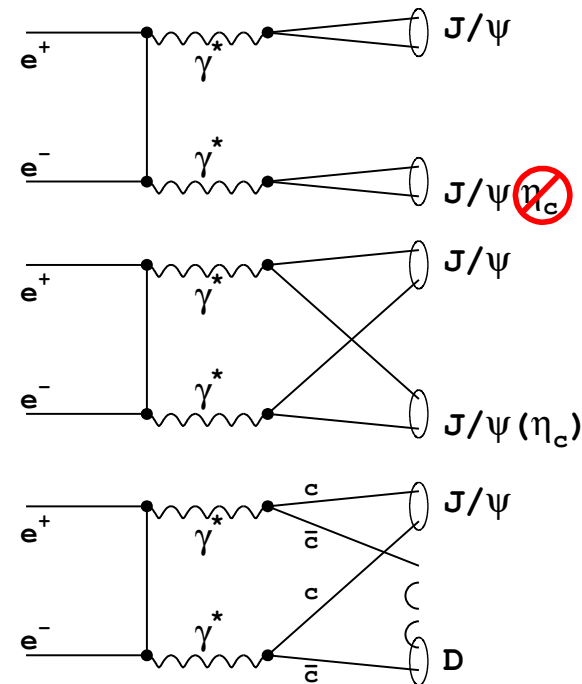
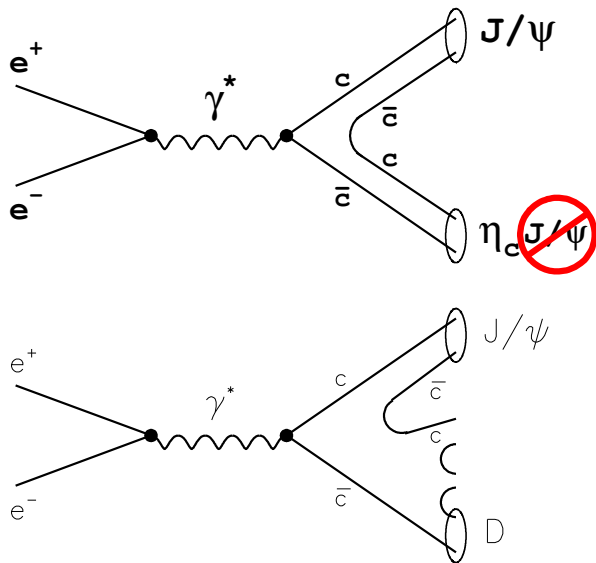

# Regge trajectories approach

- Belle results on double  $c\bar{c}$  production demonstrated that most probably PQCD calculations for  $c$  fragmentation into charmonium are invalid.
- New ( $\equiv$  well forgotten old) non-perturbative method to calculate the  $c \rightarrow J/\psi$  fragmentation is suggested by Alexey Kaidalov (*JETP Lett.* 77, p.349 (2003) & hep-ex/0301246):
  - Based on Regge trajectories approach.
  - No new free parameters in the model.
  - Calculated cross-section for  $e^+e^- \rightarrow J/\psi c\bar{c}$  is consistent with Belle results.
  - Solve the Tevatron  $\psi'$  surplus problem without appealing to CS model.  
Predicts significant fraction of prompt charmonium accompanied by another charmed hadrons.  
Can we test this with Tevatron RUN II data?

Published analysis  $\mathcal{L} = 45 \text{ fb}^{-1} \Rightarrow$  New study  $\mathcal{L} = 101 \text{ fb}^{-1}$

$p_{J/\psi} > 2 \text{ GeV}/c$  to remove  $B \rightarrow J/\psi$  decays

$N_{ch} > 4$  to suppress  $QED$

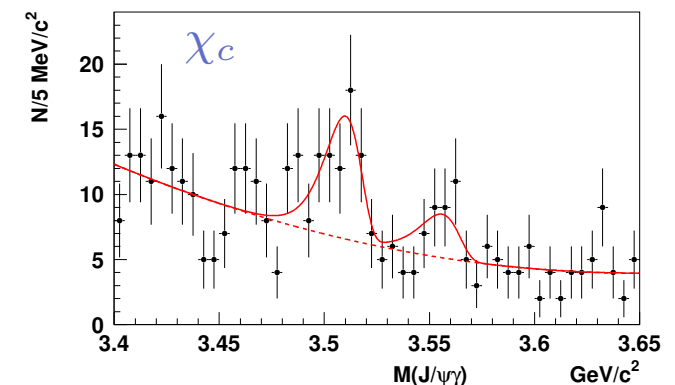
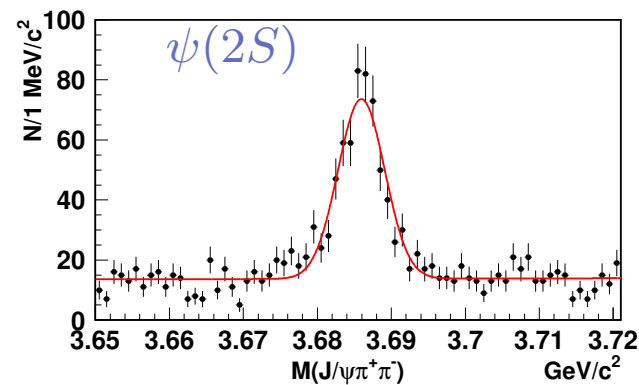
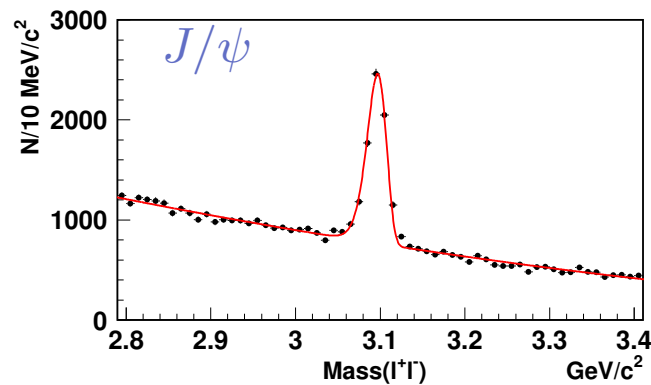

$J/\psi \rightarrow l^+l^-$ :  $N \sim 5000 \text{ ev.}$

$\psi(2S) \rightarrow J/\psi\pi^+\pi^-$ :  $N \sim 200 \text{ ev.}$

$\chi_{c1} \rightarrow J/\psi\gamma$ :  $N = 33.2_{-9.8}^{+10.5} \text{ ev.}$  (after  $\psi(2S) \rightarrow \chi_{c1}\gamma$  subtraction)

## First evidence for $\chi_{c1}$ continuum production

$$\frac{\sigma(e^+e^- \rightarrow \chi_{c1}X) |_{P_{\chi_{c1}} > 2.0 \text{ GeV}/c}}{\sigma(e^+e^- \rightarrow J/\psi X) |_{P_{J/\psi} > 2.0 \text{ GeV}/c}} = 0.107 \pm 0.035 \pm 0.032$$

## Study $J/\psi$ recoil mass spectrum around $M_{recoil} \sim 3 \text{ GeV}/c^2$

- Constrain  $J/\psi$  into nominal mass to improve resolution
- Verify recoil mass scale:  
Use  $e^+e^- \rightarrow \psi(2S)\gamma$  for calibration  
Recoil mass bias  $< 3 \text{ MeV}/c^2$
- Fit:
  - Includes all known charmonium:  
 $\eta_c, J/\psi, \chi_{c0}, \chi_{c1}, \chi_{c2}, \eta_c(2S), \psi(2S)$
  - Masses of  $\eta_c, \chi_{c0}, \eta_c(2S)$  free.

	$N$	$M [\text{GeV}/c^2]$	$\sigma$
$\eta_c$	$175 \pm 23$	$2.972 \pm 0.007$	9.9
$J/\psi$	$-9 \pm 17$	fixed	--
$\chi_{c0}$	$61 \pm 21$	$3.409 \pm 0.010$	2.9
$\chi_{c1} + \chi_{c2}$	$-15 \pm 19$	fixed	--
$\eta_c(2S)$	$108 \pm 24$	$3.630 \pm 0.008$	4.4
$\psi(2S)$	$-38 \pm 21$	fixed	--

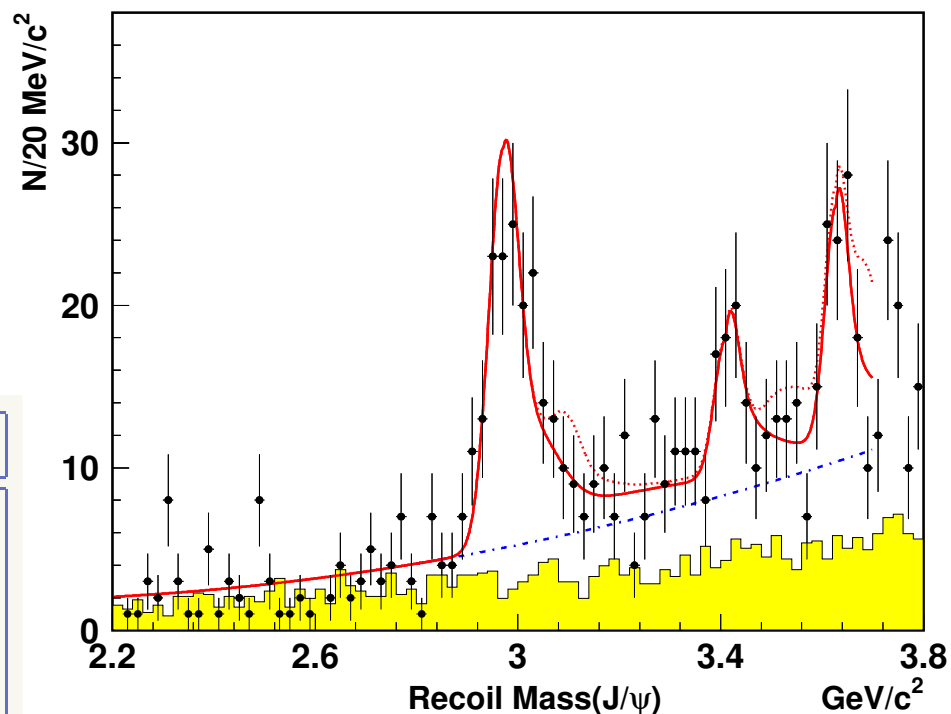

Select  $\psi(2S) \rightarrow J/\psi\pi^+\pi^-$   
 Look at Recoil mass against  $\psi(2S)$

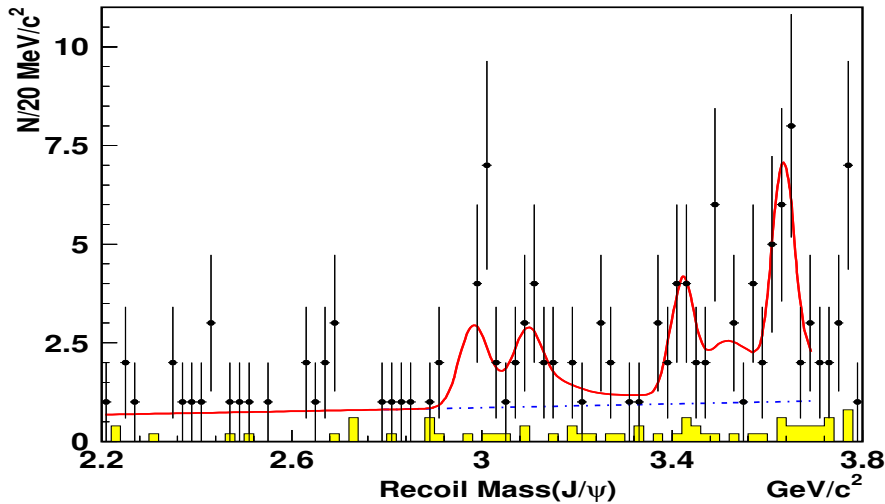

	$N$ ev.	$\sigma$
$\eta_c$	$15.8 \pm 6.9$	2.7
$J/\psi$	$13.3 \pm 7.1$	—
$\chi_{c0}$	$19.8 \pm 8.3$	3.0
$\chi_{c1} + \chi_{c2}$	$9.3 \pm 8.1$	—
$\eta_c(2S)$	$32.8 \pm 9.8$	3.9
$\psi(2S)$	$-3.1 \pm 6.8$	—

Select Recoil mass region  
 $2.8 < M_{recoil} < 3.8 \text{ GeV}/c^2$   
 Look at invariant mass  $J/\psi\gamma$

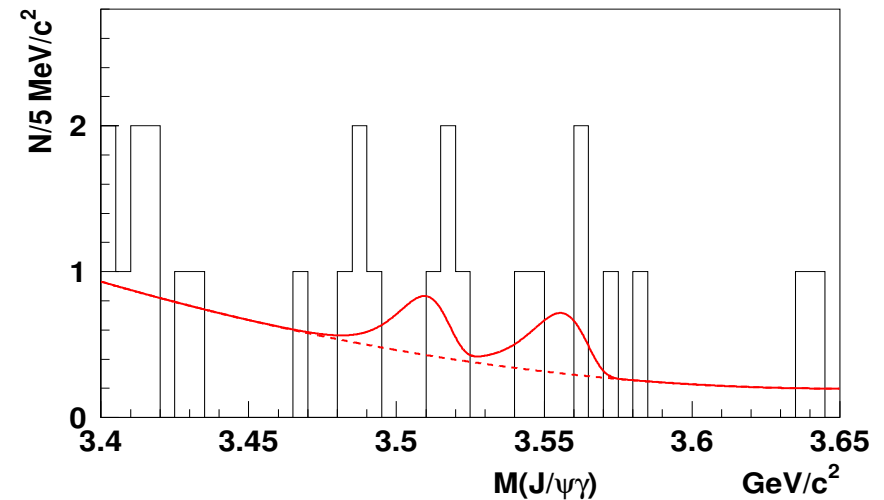

- No significant signals found  
 $N_{\chi_{c1}} = 1.8^{+3.0}_{-2.4}$  ( $< 6.8$  at 90%CL)  
 $N_{\chi_{c2}} = 2.0^{+2.6}_{-2.0}$  ( $< 6.4$  at 90%CL)
- Set Upper Limit for  
 $\sigma(e^+e^- \rightarrow \chi_{c1(2)} + \text{any } (c\bar{c})_{res})$



# Summary of double charmonium production X-section

**P R E L I M I N A R Y !**

$$\sigma(e^+e^- \rightarrow (c\bar{c})_{res}^1 (c\bar{c})_{res}^2) \times \mathcal{B}((c\bar{c})_{res}^2 \rightarrow > 2 \text{ charged}) \quad (\text{fb})$$

		R E C O N S T R U C T E D				C H A R M O N I U M		
		$\eta_c$	$J/\psi$	$\chi_{c0}$	$\chi_{c1}$	$\chi_{c2}$	$\eta_c(2S)$	$\psi(2S)$
R E C O I L C H A R M O N I U M	$\eta_c$	--	$46 \pm 6_{-9}^{+7}$	--	$< 18$	$< 20$	--	$18 \pm 8 \pm 7$
	$J/\psi$	--	$< 8$	--	$< 18$	$< 20$	--	$< 64$
	$\chi_{c0}$	--	$16 \pm 5 \pm 4$	--	$< 18$	$< 20$	--	$17 \pm 8 \pm 7$
	$\chi_{c1}$	--	$< 8$	--	$< 18$	$< 20$	--	$< 24$
	$\chi_{c2}$	--	$< 8$	--	$< 18$	$< 20$	--	$< 24$
	$\eta_c(2S)$	--	$25 \pm 6 \pm 6$	--	$< 18$	$< 20$	--	$31 \pm 9 \pm 10$
	$\psi(2S)$	--	$< 16$	--	$< 18$	$< 20$	--	$< 18$



# Improved measurement of $e^+e^- \rightarrow J/\psi c\bar{c}$

Published analysis ( $\mathcal{L} = 45 \text{ fb}^{-1}$ ): *Belle* observed  $D^{*+}$  and  $D^0$  accompanying prompt  $J/\psi$  (PRL 89, 142001 (2002))

- Special kinematical cuts against large  $B\bar{B}$  background
- Rely on LUND fragmentation rates for  $c\bar{c} \rightarrow D^0(D^{*+})$  to calculate cross-section for  $e^+e^- \rightarrow J/\psi c\bar{c}$  from  $e^+e^- \rightarrow J/\psi D^0(D^{*+})X$

Large systematic uncertainty + unknown model dependence

New analysis: more than double statistics ( $\mathcal{L} = 101 \text{ fb}^{-1}$ )

- No additional cuts
- Reconstruct all ground state charm hadrons

Reduce systematic error + remove model dependence

- Reconstruct  $D^0 \rightarrow K\pi(K3\pi)$ ,  
 $D^+ \rightarrow K2\pi$ ,  $D_s^+ \rightarrow KK\pi$  and  
 $\Lambda_c \rightarrow pK\pi$
- Fit  $D(\Lambda_c)$  signals in  $M_{\ell^+\ell^-}$  bins
- Plot the fit results in  $M_{\ell^+\ell^-}$  bins
- Find  $J/\psi$  signal in  $\ell^+\ell^-$  mass distributions:

$$N_{D^0 \rightarrow K\pi} = 49.6 \pm 13.3 \quad (3.7\sigma)$$

$$N_{D^0 \rightarrow K3\pi} = 53.0 \pm 21.2 \quad (2.5\sigma)$$

$$N_{D^+ \rightarrow K2\pi} = 56.2 \pm 15.4 \quad (3.6\sigma)$$

$$N_{D_s^+ \rightarrow KK\pi} = 23.8 \pm 9.4 \quad (2.6\sigma)$$

$$N_{\Lambda_c \rightarrow Kp\pi} = 3.0 \pm 4.2$$

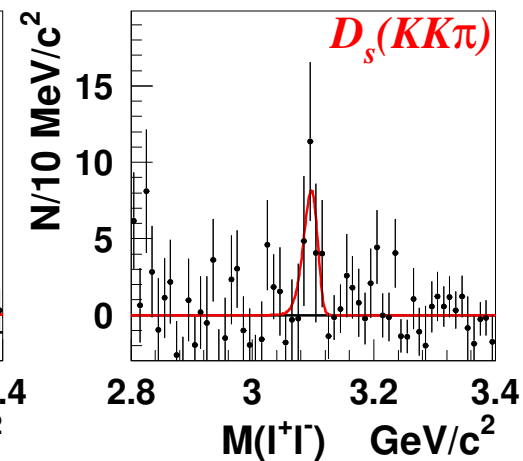
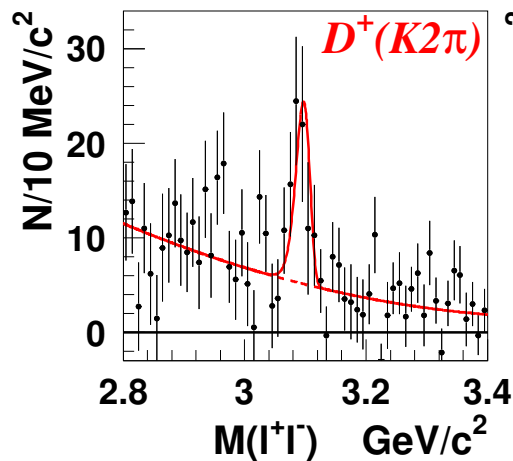
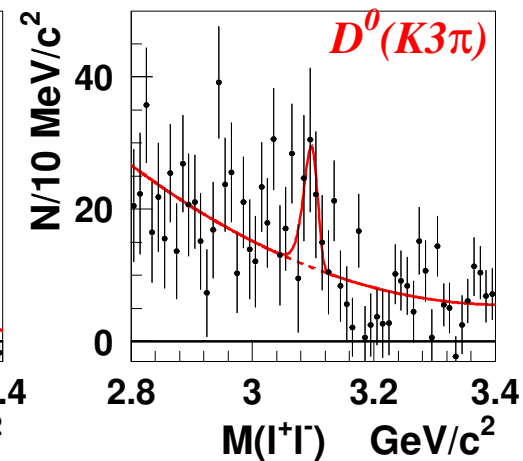
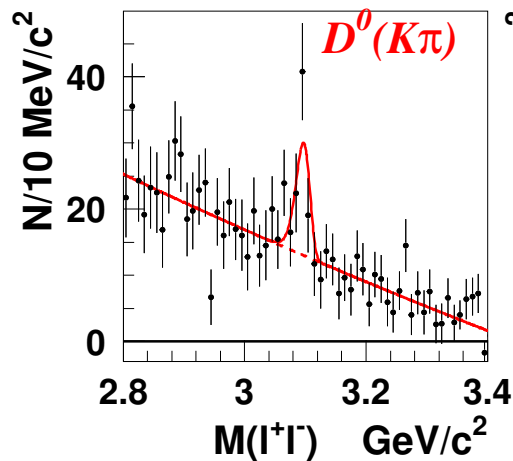

# Calculate X-section for $e^+e^- \rightarrow J/\psi c\bar{c}$

- Correct each of 5 measured yields on efficiency
- Average 5 results using LUND prediction for  $f(c\bar{c} \rightarrow D(\Lambda_c))$

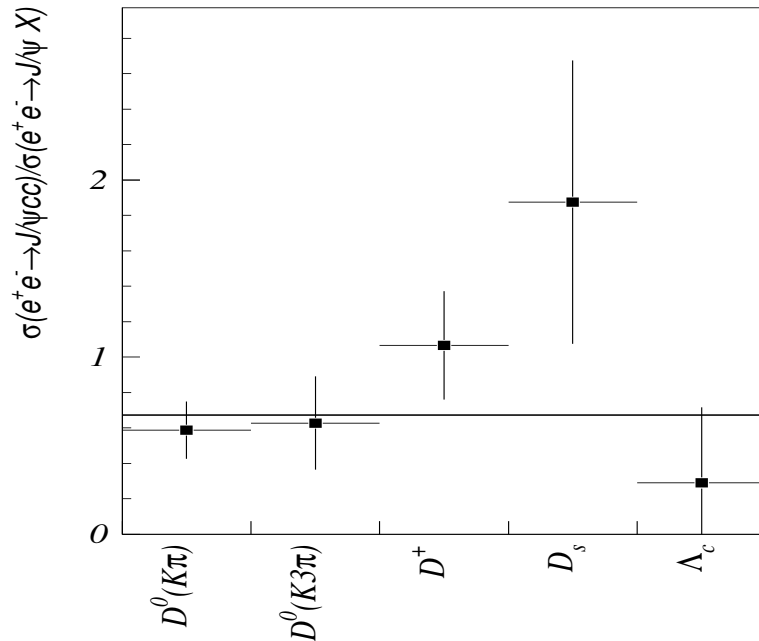

- Reasonable agreement:  $\chi^2/n.d.f. = 1.25$

$$\frac{\sigma(e^+e^- \rightarrow J/\psi c\bar{c})}{\sigma(e^+e^- \rightarrow J/\psi X)} = 0.67 \pm 0.12$$

- All final charm hadrons are reconstructed (except for  $\Xi_c$ )
- Do not need model!
- Sum over  $D^0$ ,  $D^+$ ,  $D_s^+$ ,  $\Lambda_c$  and  $(c\bar{c})_{res}$  yields

$$\frac{\sigma(e^+e^- \rightarrow J/\psi c\bar{c})}{\sigma(e^+e^- \rightarrow J/\psi X)} = 0.82 \pm 0.15 \pm 0.14$$

**PRELIMINARY !**

## New 2003 results:

- BaBar, Cleo, Belle observed  $\eta_c(2S)$  in  $\gamma\gamma$  interactions
- DELPHI observed  $J/\psi$  in  $\gamma\gamma$  interactions at  $\sqrt{s} = 161 - 207 \text{ GeV}$
- Belle updated  $e^+e^- \rightarrow 2(c\bar{c})$  analysis:
  - The published *Belle* results are confirmed with new data and analysis
  - The first evidence for prompt  $\chi_{c1}$  production.
  - Cross-sections for many pairs of double charmonium production are calculated with better accuracy or for the first time.
  - $\frac{\sigma(e^+e^- \rightarrow J/\psi c\bar{c})}{\sigma(e^+e^- \rightarrow J/\psi X)}$  is calculated with reduced systematics and model dependence.

$e^+e^-$  machines are real factories to analyze charmonium properties

- To search for new charmonium states:  
Two new states:  $\eta_c(2S)$  and  $(c\bar{c})(3872)$  are observed for last two years at  $B$ -factories.
- To study charmonium production mechanisms in  $e^+e^-$  annihilation,  $\gamma\gamma$  fusion and  $B$ -decays.
- To study charmonium decays.